

LAST Name _____ FIRST Name _____

Lab Time _____

- **(10 Points)** Print your name and lab time in legible, block lettering above AND on the last page where the grading table appears.
- This exam should take up to 120 minutes to complete. You will be given at least 120 minutes, up to a maximum of 170 minutes, to work on the exam.
- **This exam is closed book.** Collaboration is not permitted. You may not use or access, or cause to be used or accessed, any reference in print or electronic form at any time during the exam, except four double-sided 8.5" × 11" sheets of handwritten notes having no appendage. Computing, communication, and other electronic devices (except dedicated timekeepers) must be turned off. Noncompliance with these or other instructions from the teaching staff—including, for example, commencing work prematurely or continuing beyond the announced stop time—is a serious violation of the Code of Student Conduct. Scratch paper will be provided to you; ask for more if you run out. You may not use your own scratch paper.
- **The exam printout consists of pages numbered 1 through 14.** When you are prompted by the teaching staff to begin work, verify that your copy of the exam is free of printing anomalies and contains all of the fourteen numbered pages. If you find a defect in your copy, notify the staff immediately.
- **You will be given a separate document containing formulas and tables.**
- Please write neatly and legibly, because *if we can't read it, we can't grade it.*
- For each problem, limit your work to the space provided specifically for that problem. *No other work will be considered in grading your exam. No exceptions.*
- Unless explicitly waived by the specific wording of a problem, you must explain your responses (and reasoning) succinctly, but clearly and convincingly.
- We hope you do a *fantastic* job on this exam.

You may use this page for scratch work only.
Without exception, subject matter on this page will *not* be graded.

F-S06.1 (40 Points) An LTI system $F : [\mathbb{Z} \rightarrow \mathbb{R}] \rightarrow [\mathbb{Z} \rightarrow \mathbb{R}]$ is placed in a feedback composition $H : [\mathbb{Z} \rightarrow \mathbb{R}] \rightarrow [\mathbb{Z} \rightarrow \mathbb{R}]$, as shown in the figure below:

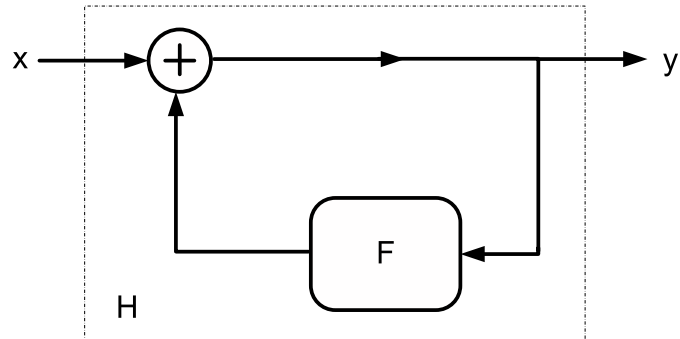

The signals x and y denote the input and output of the composite system, respectively. The frequency response $F : \mathbb{R} \rightarrow \mathbb{C}$ of the system F is characterized by

$$\forall \omega, \quad F(\omega) = \frac{1}{4} e^{-i2\omega}.$$

- (a) Determine an expression for $H(\omega), \forall \omega$, where $H : \mathbb{R} \rightarrow \mathbb{C}$ is the frequency response of the composite system H .

- (b) Determine a linear, constant-coefficient difference equation governing the input-out behavior of the composite system H . What are the dimensions of the matrices $[A, B, C, D]$ in a *smallest-order* state-space representation of H ?

(c) Determine the impulse response $h : \mathbb{Z} \rightarrow \mathbb{R}$ by finding a simple expression for $h(n), \forall n$.

(d) Determine an exact numerical value for each of the following infinite sums. Based on your results, determine which frequency band(s) (low, mid-range, high) the composite system H —if viewed as a filter—attenuates and which band(s) it amplifies (or passes through without substantial attenuation).

$$(i) \sum_{n=-\infty}^{\infty} h(n) =$$

$$(ii) \sum_{n=-\infty}^{\infty} (-1)^n h(n) =$$

$$(iii) \sum_{n=-\infty}^{\infty} i^n h(n) =$$

F-S06.2 (50 Points) The main parts (a) and (b) of this problem are mutually independent; you may tackle them in either order.

- (a) Consider a discrete-time *memoryless* system $F : [\mathbb{Z} \rightarrow \mathbb{Z}] \rightarrow [\mathbb{Z} \rightarrow \mathbb{Z}]$ having input signal x and corresponding output signal y . If the input x is $\forall n, x(n) = n$, the output y is the *even* signal shown below:

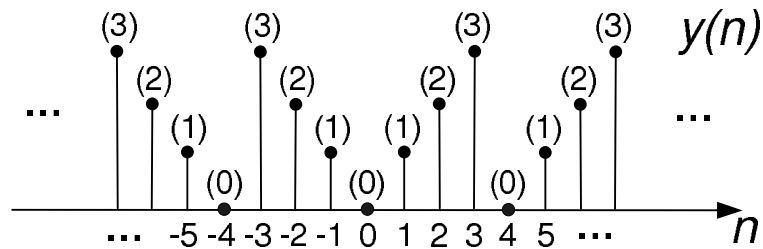

- (i) Determine the response of the system to the finite-length input signal x characterized as follows:

$$\forall n, x(n) = 8\delta(n+1) - 3\delta(n) + \delta(n-1) - 5\delta(n-3) - 4\delta(n-5).$$

Provide a well-labeled stem plot ("lolly-pop" diagram) of the corresponding output signal y , i.e., specify $y(n), \forall n$.

- (ii) Select the strongest assertion from the choices below. Explain your choice.
- (I) The system must be linear.
 - (II) The system could be linear.
 - (III) The system cannot be linear.

- (b) In an analog communication scheme, known as *phase modulation*, an information-bearing signal $x : \mathbb{R} \rightarrow \mathbb{R}$ having values $x(t)$ is used to vary the phase of a sinusoidal carrier signal $c : \mathbb{R} \rightarrow \mathbb{R}$, described by

$$\forall t, \quad c(t) = \cos(\omega_c t + \theta_c(t)),$$

where $\omega_c \gg 1$, and θ_c denote the carrier frequency and instantaneous phase, respectively. A phase-modulator $T : [\mathbb{R} \rightarrow \mathbb{R}] \rightarrow [\mathbb{R} \rightarrow \mathbb{R}]$ —viewed as a system whose input signal is x —produces an output signal $y : \mathbb{R} \rightarrow \mathbb{R}$, which is then transmitted over the airwaves. The signal y is characterized as follows:

$$\forall t, \quad y(t) = \cos(\omega_c t + \alpha x(t)), \quad \exists \alpha > 0.$$

- (i) Select the strongest assertion from the choices below. Explain your choice.

- (I) The system must be linear.
- (II) The system could be linear.
- (III) The system cannot be linear.

- (ii) Select the strongest assertion from the choices below. Explain your choice.

- (I) The system must be causal.
- (II) The system could be causal.
- (III) The system cannot be causal.

- (iii) Select the strongest assertion from the choices below. Explain your choice.

- (I) The system must be memoryless.
- (II) The system could be memoryless.
- (III) The system cannot be memoryless.

- (iv) Select the strongest assertion from the choices below. Explain your choice.

- (I) The system must be time invariant.
- (II) The system could be time invariant.
- (III) The system cannot be time invariant.

F-S06.3 (50 Points) Consider a causal, discrete-time, single-input single-output (SISO) system whose $[A, B, C, D]$ state-space representation is given by the state-update equation

$$\underbrace{\begin{bmatrix} q_1(n+1) \\ q_2(n+1) \end{bmatrix}}_{\mathbf{q}(n+1)} = \underbrace{\begin{bmatrix} 1/2 & 5/2 \\ 0 & 3 \end{bmatrix}}_{\mathbf{A}} \underbrace{\begin{bmatrix} q_1(n) \\ q_2(n) \end{bmatrix}}_{\mathbf{q}(n)} + \underbrace{\begin{bmatrix} 1 \\ 0 \end{bmatrix}}_{\mathbf{B}} x(n)$$

and the output equation

$$y(n) = \underbrace{\begin{bmatrix} 1 & 1 \end{bmatrix}}_{\mathbf{C}} \mathbf{q}(n).$$

Note that $D = \mathbf{0}$ for this system.

The input signal, the state response, and the output response are $x : \mathbb{N}_0 \rightarrow \mathbb{R}$, $\mathbf{q} : \mathbb{N}_0 \rightarrow \mathbb{R}^2$, and $y : \mathbb{N}_0 \rightarrow \mathbb{R}$, respectively.

- (a) Determine the modes $(\lambda_1, \mathbf{v}_1)$ and $(\lambda_2, \mathbf{v}_2)$ of the system, and explain why the system is unstable.

- (b) *For this part only*, suppose the input signal x is zero (i.e., $x(n) = 0, \forall n \geq 0$) and the initial state

$$\mathbf{q}(0) = \begin{bmatrix} 3 \\ 2 \end{bmatrix}.$$

Determine a simple expression for $\mathbf{q}(n)$, the state of the system at time n ($\forall n \geq 1$).

- (c) Assume the initial state is zero (i.e., $\mathbf{q}(0) = \mathbf{0}$). Determine a simple closed-form expression for $h(n), \forall n \in \mathbb{Z}$, where $h : \mathbb{Z} \rightarrow \mathbb{R}$ is the impulse response of the system. Express your answer in terms of the mode parameters $\lambda_1, \lambda_2, \mathbf{v}_1$, and \mathbf{v}_2 .

(d) Assume the initial state

$$\mathbf{q}(0) = \begin{bmatrix} 3 \\ 2 \end{bmatrix}.$$

Your friend Fran puts an opaque box around the system, and allows you only to apply an arbitrary input signal x to the system and measure the corresponding output response y . Fran does not allow you unfettered access to measure the state variables (i.e., you cannot peek inside the box; you can only perform an input-output analysis of the system).

Fran claims that at some point in time you will (quite unexpectedly) see smoke billowing from the box, because you can never detect the presence of the unstable mode in the output response; that is, you cannot detect the growth of a state variable as $n \rightarrow \infty$. Is Fran correct? Explain your reasoning succinctly, but clearly and convincingly.

You may use the blank space below for scratch work. Nothing written below this line on this page will be considered in evaluating your work.

- (e) Assume the initial state is zero (i.e., $\mathbf{q}(0) = \mathbf{0}$). You have been commissioned to design the input sequence $x(0), x(1), \dots$ so that at time $n = N$ the system reaches a desired target state $\mathbf{q}(N) = \mathbf{q}_{\text{target}}$. If there is an $N \in \mathbb{N}$ such that this is feasible, the target state $\mathbf{q}_{\text{target}}$ is said to be *reachable* in N steps. If no such finite N can be found, the state is called *unreachable*.

For each of the following target states, explain whether it is reachable or unreachable. If it is reachable, specify N , the *minimum* number of steps it takes to drive the system to that target state (i.e., specify the minimum N such that $\mathbf{q}(N) = \mathbf{q}_{\text{target}}$), and determine the input signal values $x(n), n = 0, 1, 2, \dots, N - 1$ that can be applied to the system (which is initially at rest) to drive the system to the target state in the minimum N steps.

If the target state is not reachable (i.e., if $N = \infty$), state so and explain why it is not reachable.

$$\mathbf{q}_{\text{target},1} = \begin{bmatrix} \sqrt{\pi} \\ 0 \end{bmatrix} \quad \mathbf{q}_{\text{target},2} = \begin{bmatrix} 0 \\ 1 \end{bmatrix}.$$

Specify the subset of the two-dimensional state-space \mathbb{R}^2 where the reachable states are located. If every state $\mathbf{q}(n) \in \mathbb{R}^2$ is reachable, state so. In any event, explain your reasoning succinctly, but clearly and convincingly.

F-S06.4 (50 Points) Consider a signal $x : \mathbb{R} \rightarrow \mathbb{R}$ which has a continuous-time Fourier transform (CTFT) $X : \mathbb{R} \rightarrow \mathbb{C}$ described below:

$$\forall \omega, \quad X(\omega) = e^{-a|\omega|}, \quad \exists a > 0.$$

- (a) Determine a simple expression for $x(t), \forall t$. This should *not* involve sophisticated mathematical manipulation.

- (b) The figure below shows the signal x being sampled by an infinite-duration train of continuous-time impulses (a train of Dirac delta functions). The output of the impulse-train sampling is the signal x_p .

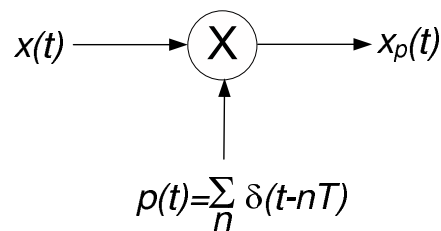

The sampling period is denoted by T seconds and the sampling frequency by $\omega_s = 2\pi/T$ radians per second.

Provide a well-labeled sketch of $X_p(\omega), \forall \omega$, the CTFT of the signal x_p (do *not* bother performing point-wise addition of functions in either the time or frequency domain). Explain why aliasing cannot be avoided, no matter how high a sampling frequency ω_s is employed. Your answer in this part should not depend on your answer to part (a).

- (c) To avoid the aliasing phenomenon of part (b), before we sample the signal x we pass it through an anti-aliasing LTI filter $H : [\mathbb{R} \rightarrow \mathbb{R}] \rightarrow [\mathbb{R} \rightarrow \mathbb{R}]$ whose frequency response characteristics are shown in the figure below.

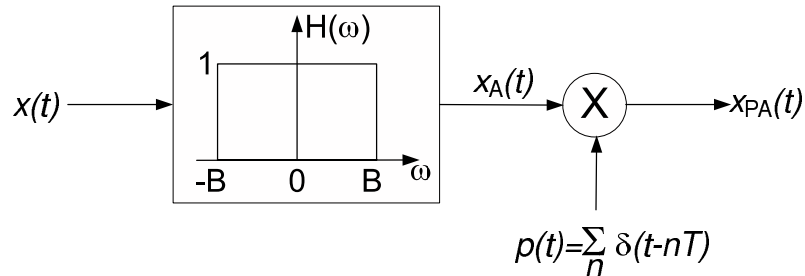

- (i) Provide a well-labeled sketch of $X_A(\omega), \forall \omega$, the spectrum of the anti-aliased signal x_A . What is the maximum bandwidth B allowed for the anti-aliasing filter H , which can theoretically avoid aliasing? Your answer must be either in terms of the sampling period T or the sampling frequency ω_s .

Corresponding to the maximum value of B you obtained above, provide a well-labeled sketch of $X_{PA}(\omega), \forall \omega$, the spectrum of the sampled signal x_{PA} .

- (ii) To capture the information discarded from the signal x by the anti-aliasing filter H , define an error signal $e : \mathbb{R} \rightarrow \mathbb{R}$ as follows:

$$\forall t, \quad e(t) = x(t) - x_A(t).$$

Provide a sketch of $E(\omega), \forall \omega$, the spectrum of the error signal e , and determine a simple expression for

$$\mathcal{E}_e = \int_{-\infty}^{+\infty} e^2(t) dt,$$

the energy of the error signal e . Your answer should be in terms of the bandwidth B and parameter a (in the description of the signal x or CTFT X). What happens to the energy \mathcal{E}_e of the error signal, in the limit $B \rightarrow \infty$? Explain your answer. Also, using *only* your expression for \mathcal{E}_e , determine \mathcal{E}_x , the energy of the signal x .

LAST Name _____ FIRST Name _____

Lab Time _____

Problem Name	Points	Your Score
1	40	
2	50	
3	50	
4	50	
Total	200	