

LAST Name \_\_\_\_\_ FIRST Name \_\_\_\_\_

Lab Time \_\_\_\_\_

- **(10 Points)** Print your name and lab time in legible, block lettering above AND on the last page where the grading table appears.
- This exam should take up to 120 minutes to complete. You will be given at least 120 minutes, up to a maximum of 170 minutes, to work on the exam.
- **This exam is closed book.** Collaboration is not permitted. You may not use or access, or cause to be used or accessed, any reference in print or electronic form at any time during the exam, except three double-sided 8.5" × 11" sheets of handwritten notes having no appendage. Computing, communication, and other electronic devices (except dedicated timekeepers) must be turned off. Noncompliance with these or other instructions from the teaching staff—including, for example, commencing work prematurely or continuing beyond the announced stop time—is a serious violation of the Code of Student Conduct. Scratch paper will be provided to you; ask for more if you run out. You may not use your own scratch paper.
- **The exam printout consists of pages numbered 1 through 14.** When you are prompted by the teaching staff to begin work, verify that your copy of the exam is free of printing anomalies and contains all of the fourteen numbered pages. If you find a defect in your copy, notify the staff immediately.
- **You will be given a separate document containing formulas and tables.**
- Please write neatly and legibly, because *if we can't read it, we can't grade it.*
- For each problem, limit your work to the space provided specifically for that problem. *No other work will be considered in grading your exam. No exceptions.*
- Unless explicitly waived by the specific wording of a problem, you must explain your responses (and reasoning) succinctly, but clearly and convincingly.
- We hope you do a *fantastic* job on this exam.

**The  $\mathcal{Z}$ -transform of a signal  $x : \mathbb{Z} \rightarrow \mathbb{C}$ :**

$$\widehat{X}(z) = \sum_{n=-\infty}^{+\infty} x(n)z^{-n}.$$

**A couple of  $\mathcal{Z}$ -transform pairs:**

$$\begin{aligned} \alpha^n u(n) &\xleftrightarrow{\mathcal{Z}} \frac{1}{1 - \alpha z^{-1}}, \quad |z| > |\alpha|. \\ \alpha^n \cos(\omega_0 n) u(n) &\xleftrightarrow{\mathcal{Z}} \frac{1 - \alpha \cos(\omega_0) z^{-1}}{1 - 2\alpha \cos(\omega_0) z^{-1} + \alpha^2 z^{-2}}, \quad |z| > \alpha > 0. \end{aligned}$$

**The Laplace transform of a signal  $x : \mathbb{R} \rightarrow \mathbb{C}$ :**

$$\widehat{X}(s) = \int_{-\infty}^{+\infty} x(t) e^{-st} dt.$$

**Some Laplace transform pairs:**

$$\begin{aligned} u(t) &\xleftrightarrow{\mathcal{L}} \frac{1}{s}, \quad \operatorname{Re}(s) > 0 \\ e^{-\alpha t} u(t) &\xleftrightarrow{\mathcal{L}} \frac{1}{s + \alpha}, \quad \operatorname{Re}(s) > -\alpha \\ e^{-\alpha t} \sin(\omega_0 t) u(t) &\xleftrightarrow{\mathcal{L}} \frac{\omega_0}{(s + \alpha)^2 + \omega_0^2}, \quad \operatorname{Re}(s) > -\alpha \end{aligned}$$

$\alpha \in \mathbb{R}$  in the above Laplace transform pairs.

**F-S07.1 (40 Points)** A plant with transfer function

$$H_2(s) = \frac{s + 1}{s(s - 1)}$$

is arranged in a feedback configuration with a proportional controller  $K$ , as shown in the figure below.

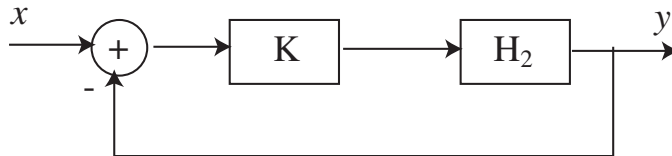

(a) What is the closed-loop transfer function?

(b) For what values of  $K$  is the closed-loop system BIBO stable?

(c) What is the impulse response of the closed-loop system for  $K = 1$ ?

(d) Suppose  $K = 6$  and  $x(t) = u(t)$ , the unit step.

Determine  $y(t), t \geq 0$ . Express  $y$  in terms of its transient and steady-state components,

$$y(t) = y_{\text{tr}}(t) + y_{\text{ss}}(t).$$

**F-S07.2 (40 Points)** Consider the acoustic environment of a lecture hall, where  $x$  denotes the sound created by a speaker, and  $y$  the speaker's sound as heard by a listener's ear. The physical characteristics of the hall produce acoustic distortion in the speaker's sound; what the listener hears is not the same as what the speaker utters.

Suppose that a particular lecture hall produces linear, time-invariant acoustic distortion. Therefore, it can be well-modeled by a discrete-time LTI system  $F : [\mathbb{Z} \rightarrow \mathbb{C}] \rightarrow [\mathbb{Z} \rightarrow \mathbb{C}]$  whose input  $x$  is the speaker's utterance and whose output  $y$  is the speaker's sound as perceived by the listener.

In particular, suppose the input-output model of the lecture hall is modeled by the linear, constant-coefficient difference equation

$$y(n) - 2 \operatorname{Re}(a) y(n-1) + |a|^2 y(n-2) = x(n-1),$$

where  $a \in \mathbb{C}$  is a parameter that models the acoustic resonance properties of the hall and is within the unit circle (i.e.,  $|a| < 1$ ).

- (a) Determine  $\widehat{F}$ , the system function of the hall. Your expression must be in terms of the resonance parameter  $a$ . Write the expression for  $\widehat{F}$  so that its denominator is a product of two first-order factors.
- (b) Suppose the resonance parameter  $a = 0.99 e^{i\pi/4}$ . Provide both a well-labeled pole-zero diagram for  $\widehat{F}$  and a well-labeled, but otherwise rough, sketch of the magnitude of the frequency response  $|F(\omega)|, \forall \omega \in [-\pi, +\pi]$ .

We want to upgrade the public address system in the lecture hall to correct for the distortion caused by the hall's acoustic environment. The upgrade includes a compensator that allows listeners to hear all the frequencies in a speaker's sound equally well. Such a compensator is called an *equalizer*.

- (c) Suppose the equalizer is a DT-LTI system  $G$ , and is simply the inverse of the system  $F$ . That is,

$$\hat{G}(z) = \frac{1}{\hat{F}(z)}.$$

Determine the impulse response  $g$  of the proposed equalizer  $G$ . Explain why such a system cannot be used as a *real-time* equalizer to correct for the lecture hall's acoustic distortion, even if our DT-LTI model of the lecture hall is reasonably accurate.

- (d) Another proposal is to construct an equalizer that *approximates* the inverse of the lecture hall's DT-LTI model, but is real-time implementable. The proposal is to design an equalizer according to the following feedback configuration:

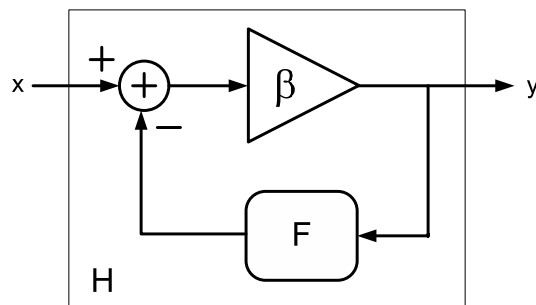

Suppose the equalizer is designed so that  $|\beta \hat{F}(z)| \gg 1$ . Explain why this proposed equalizer is a reasonably good choice to correct for the distortion of the lecture hall; in particular, explain why such an equalizer is implementable in real time.

**F-S07.3 (60 Points)** The *bilinear transformation* is a tool for designing a discrete-time LTI filter from a continuous-time counterpart.

The process begins with an already-designed analog filter having system function  $\widehat{H}_c$ . The discrete-time filter is then obtained by letting

$$s = \frac{2}{T} \frac{1 - z^{-1}}{1 + z^{-1}} \quad (1)$$

in the system function expression  $\widehat{H}_c(s)$ , where  $T > 0$  is a parameter whose value is chosen based on convenience.

Simply put, the system function  $\widehat{H}_d$  of the discrete-time filter is designed from its continuous-time counterpart according to the equation

$$\widehat{H}_d(z) = \widehat{H}_c(s) \Big|_{s = \frac{2}{T} \frac{1 - z^{-1}}{1 + z^{-1}}}$$

- (a) Show that the bilinear transformation maps every point in the left-half of the  $s$ -plane to a corresponding point inside the unit circle in the  $z$ -plane. To do this, first use Equation 1 to express  $z$  in terms of  $s$ . Next, write  $s$  in its Cartesian form  $s = \sigma + i\omega$ , and show that if  $\sigma < 0$ , then  $|z| < 1$ .

- (b) Show that the  $i\omega$ -axis in the  $s$ -plane maps to the unit circle in the  $z$ -plane. Do this by demonstrating that if  $s = i\omega$ , then  $|z| = 1$ .

(c) True or false?

A discrete-time filter obtained by applying the bilinear transformation to a continuous-time filter is causal and stable, if the continuous-time filter is causal and stable.

Explain your reasoning succinctly, but clearly and convincingly.

(d) The result of part (b) suggests a relationship between the continuous-time frequency variable  $\omega$  (having units of radians/sec) and the frequency variable  $\Omega$  (having units of radians/sample) of the corresponding discrete-time filter.

Use the result of part (b) to show that  $s = i\omega$  and  $z = e^{i\Omega}$  can be inserted in Equation 1 to establish the following relationship between the two frequency variables:

$$\omega = \frac{2}{T} \tan\left(\frac{\Omega}{2}\right) \quad \text{or, equivalently,} \quad \Omega = 2 \arctan\left(\frac{\omega T}{2}\right).$$



- (e) The magnitude of the frequency response of a continuous-time LTI filter is shown in the figure below.

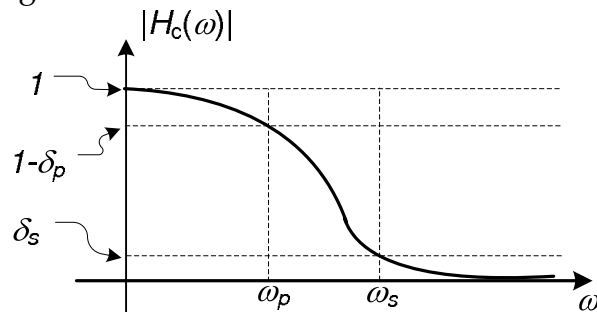

The frequency  $\omega_p$  defines the boundary of the filter's passband cutoff frequency, and the frequency  $\omega_s$  demarcates the beginning of the stopband.

The quantity  $1 - \delta_p$  specifies the minimum passband gain and the quantity  $\delta_s$  specifies the maximum stopband gain.

Use the result of part (d) to provide a well-labeled magnitude response plot of the discrete-time filter obtained by applying the bilinear transformation of Equation 1 to the continuous-time filter above.

- (f) The system function  $\hat{H}_c$  of a continuous-time, causal, and stable  $N^{\text{th}}$ -order Butterworth filter satisfies the following equation:

$$\hat{H}_c(s) \hat{H}_c(-s) = \frac{1}{1 + \left(\frac{s}{i\omega_c}\right)^{2N}},$$

where  $\omega_c$  is a positive frequency.

A discrete-time filter  $H_d$  is designed by applying the bilinear transformation of Equation 1 (with  $T = 2$ ) to the  $N^{\text{th}}$ -order continuous-time Butterworth filter  $H_c$ . In particular, the system function  $\hat{H}_d$  of the discrete-time "Butterworth filter" satisfies the following equation:

$$\hat{H}_d(z) \hat{H}_d(1/z) = \frac{1}{1 + \left(\frac{s}{i\omega_c}\right)^{2N}} \bigg|_{s=\frac{1-z^{-1}}{1+z^{-1}}}.$$

Determine the response of the discrete-time filter  $H_d$  to the input signal  $x_d(n) = (-1)^n, \forall n \in \mathbb{Z}$ .

**F-S07.4 (50 Points)** A continuous-time, causal, LTI filter  $H_c$  has a real-valued impulse response  $h_c$  and a rational transfer function  $\hat{H}_c$ .

A simple input-output graphical depiction of the filter is

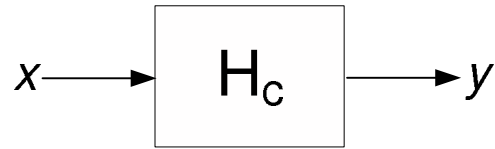

The pole-zero diagram of the filter is shown below. Note that the transfer function does *not* have a finite-valued zero.

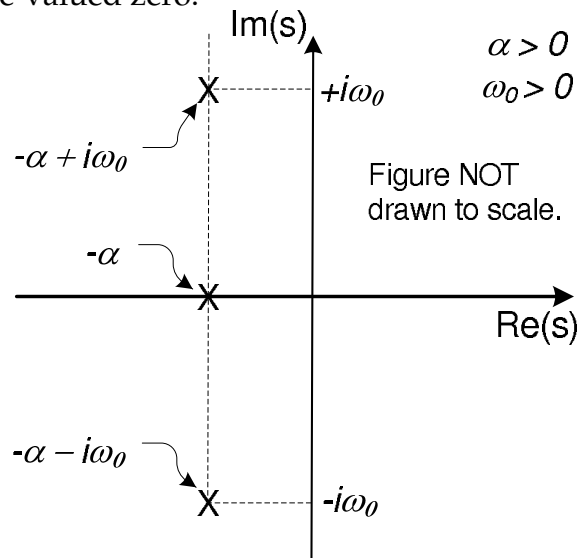

- (a) If the input signal  $x$  is characterized by  $x(t) = 1, \forall t$ , the corresponding output signal is

$$y(t) = \frac{1}{\alpha(\alpha^2 + \omega_0^2)}, \quad \forall t.$$

Determine a fairly simple expression for the transfer function  $\hat{H}_c(s)$ .

(b) Suppose the input signal  $x$  is the unit step:  $x(t) = u(t)$ . Determine a simple expression for  $y_{ss}(t)$ , the corresponding steady-state response of the filter.

(c) Determine a fairly simple expression for, and provide a well-labeled sketch of,  $h_c(t)$ .

- (d) We wish to use the *impulse invariance* method to design a discrete-time LTI filter  $H_d$  from the continuous-time LTI filter  $H_c$ . According to this method, the impulse response values  $h_c(t)$  are sampled to produce the discrete-time filter's impulse response values  $h_d(n)$ . In particular,

$$h_d(n) = T h_c(nT), \quad \forall n \in \mathbb{Z},$$

where  $T > 0$  is the sampling period. Let  $\widehat{H}_d$  denote the transfer function of the discrete-time filter.

It turns out that the discrete-time filter has exactly two finite zeroes (at  $z = 0$  and  $z = -e^{-\alpha T}$ ) and exactly one zero at  $|z| = +\infty$ . Do *not* attempt to show this, as it involves algebraic manipulations far beyond the scope of this problem. Instead, simply treat as factual the information about the zero locations, and focus on drawing inferences from it about the number of poles.

- (i) Determine a simple expression for each of the poles of  $\widehat{H}_d(z)$ ; your expressions must be in terms of a subset of the parameters  $\alpha$ ,  $T$ , and  $\omega_0$ . Please note that you are *not* being asked to determine an expression for the transfer function  $\widehat{H}_d$ .

- (ii) Provide a well-labeled pole-zero diagram for  $\widehat{H}_d$ , assuming  $\alpha = 1$ ,  $\omega_0 = 2\pi \cdot 1000$ , and  $T = \frac{1}{6000}$ .

- (iii) Determine the RoC of the transfer function  $\widehat{H}_d$ , and state whether the discrete-time filter is causal, BIBO stable, neither, or both.

LAST Name \_\_\_\_\_ FIRST Name \_\_\_\_\_

Lab Time \_\_\_\_\_

Problem Name	Points	Your Score
1	40	
2	40	
3	60	
4	50	
<b>Total</b>	<b>200</b>	