

EECS 40 Midterm #1

Fall 2001

Professor Oldham

Guidelines:

1. Closed book and notes except 1 page of formulas.
2. You may use a calculator
3. Do not unstaple the midterm.
4. Show all your work and reasoning on the exam in order to receive full or partial credit.
5. This exam contains 6 problems and corresponding worksheets plus the cover page.
6. Do not ask questions during the exam. If you believe there is an error, please point it out. If you believe there is an ambiguity, explain your interpretation in your answer.

Problem 1 (15 points)

Hint: Use the easiest possible method to solve these problems.

(a) In the circuit below, find V_A , V_B , V_C .

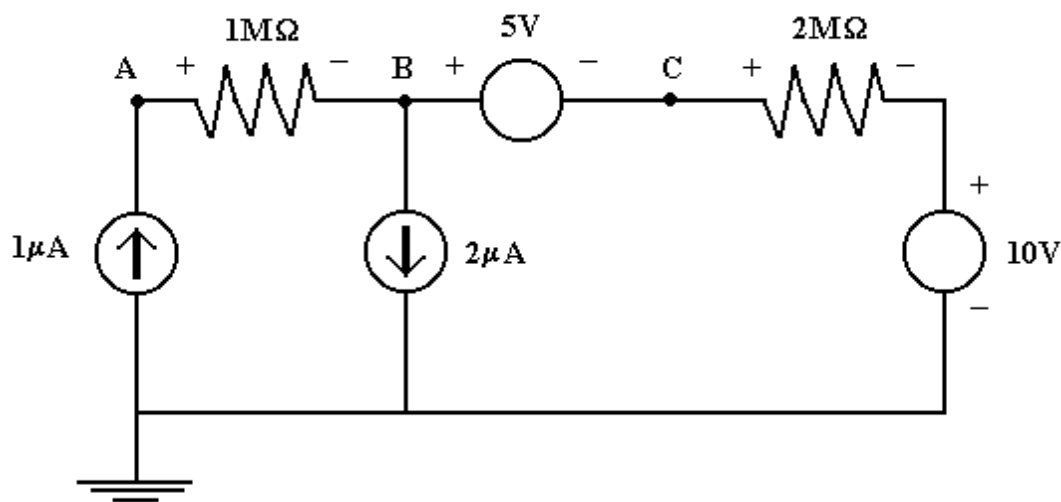

(b) In the circuit below, find V_A , V_B , V_C .

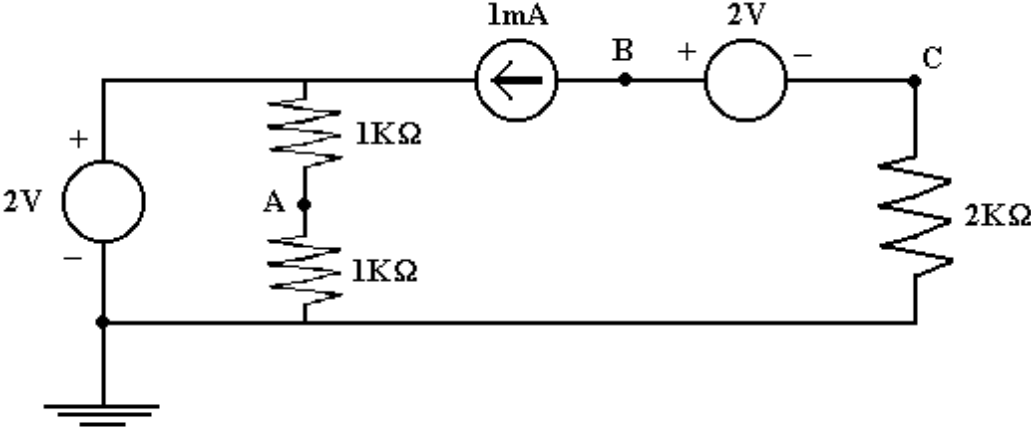

(c) Calculate a sufficient number of points to draw the I versus V characteristics of the following circuit. Draw the graph on the axes provided. Be sure the label the axes.

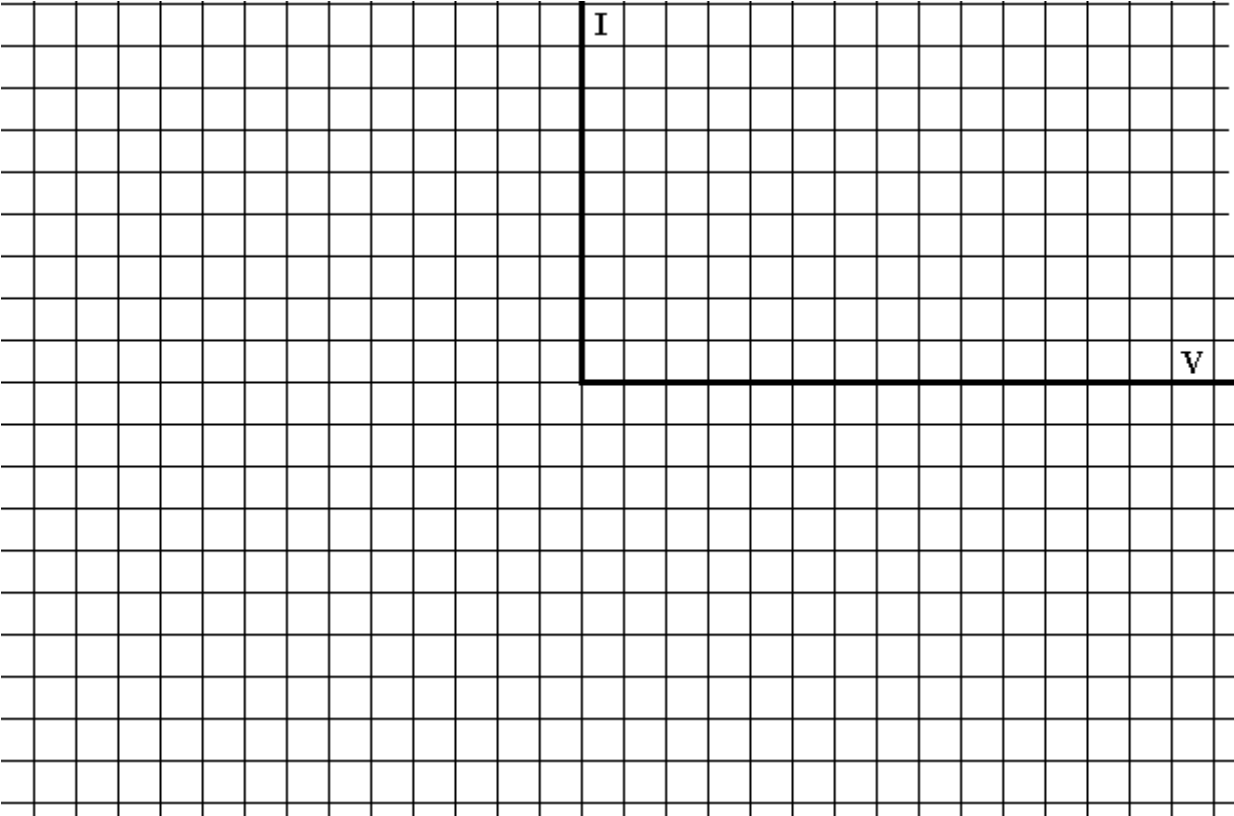
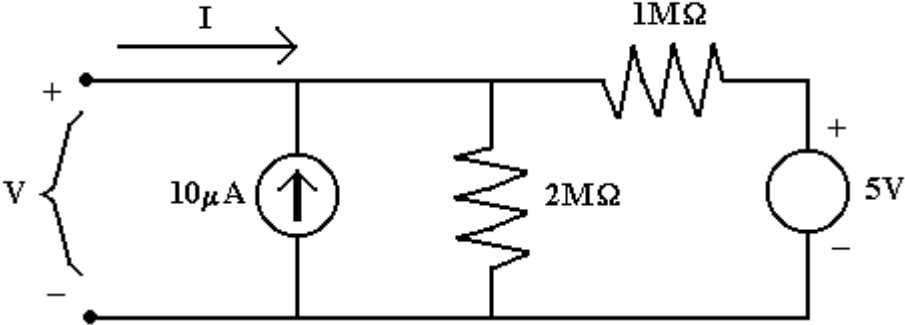

Problem 2 (21 points)

The switch is to the left (A connected to B) for a very long time prior to $t = 0$, at which time the switch suddenly swings to the right (connecting B to D).

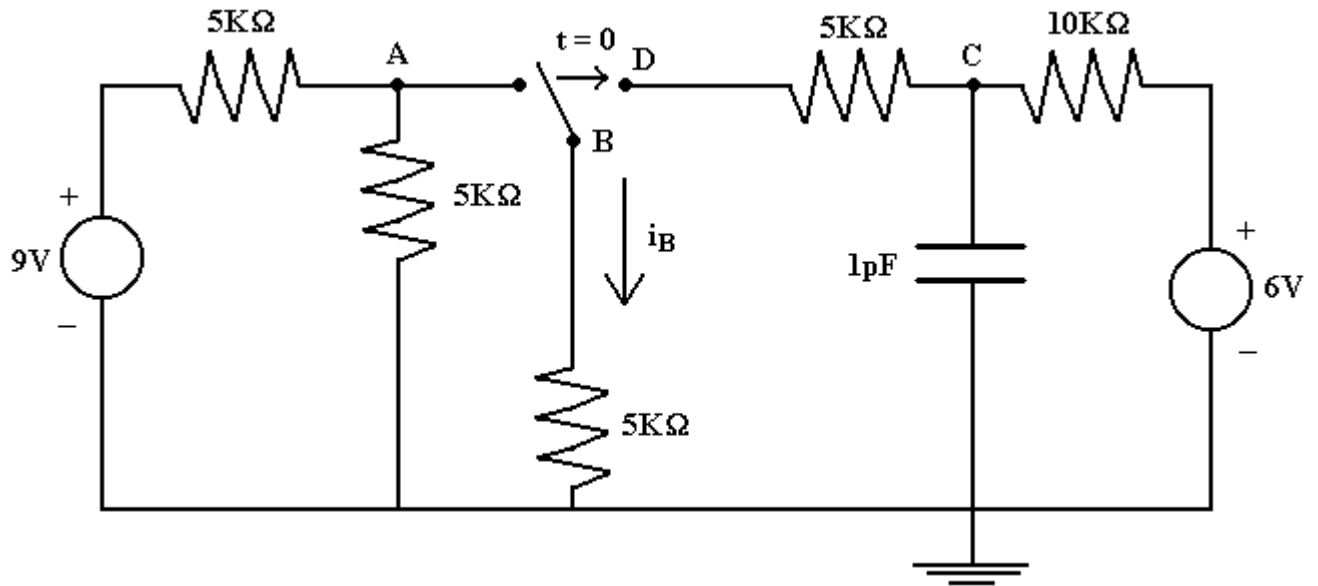

- What are the values of V_A , V_B , V_C , V_D , i_B at $t = 0^-$?
- What are the values of V_A , V_B , V_C , V_D , i_B at $t = 0^+$?
- What are the values of V_A , V_B , V_C , V_D , i_B at $t \gg 0$?
- On the axes, please make a neat sketch of $V_C(t)$. Label the axes.

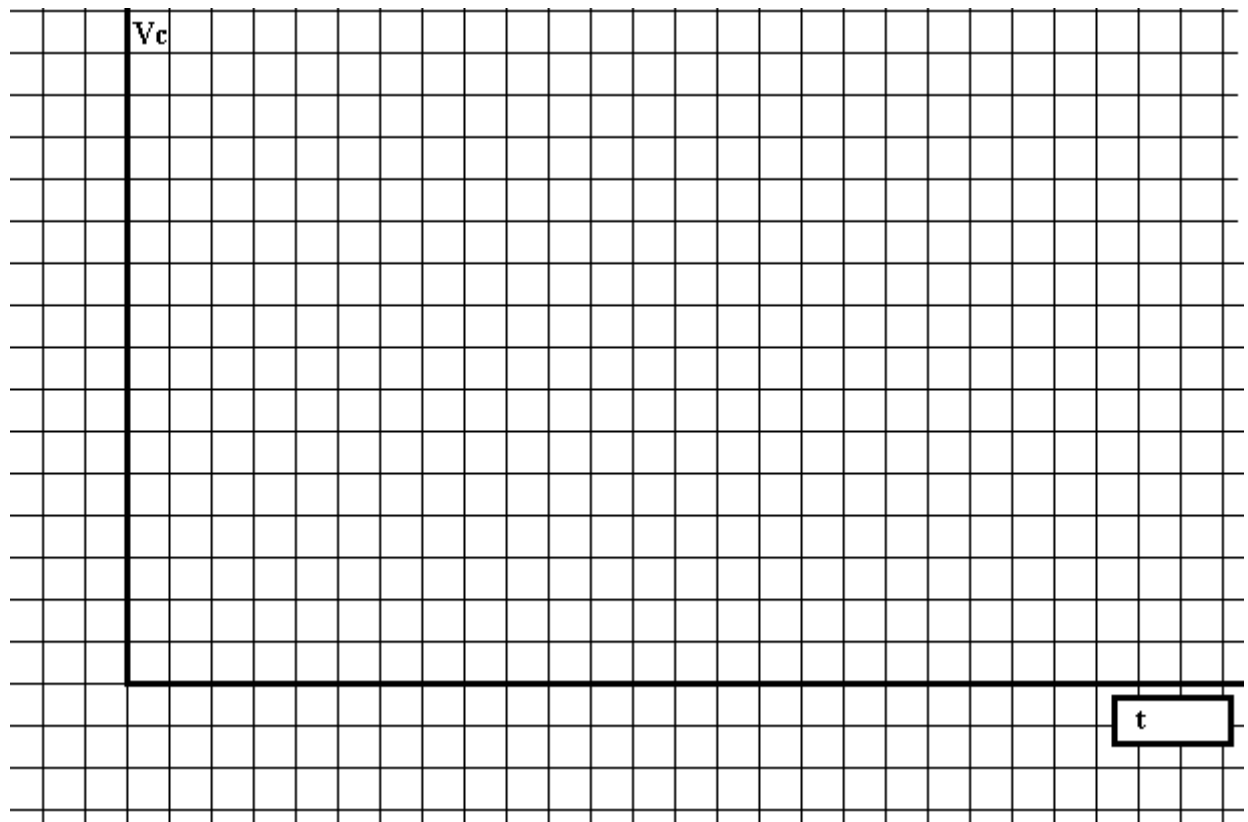

(e) Write an equation for $V_C(t)$.

Problem 3 (17 points)

A three-digit binary number ABC has "even parity" if an even number of its digits is 1 or none of its digits is 1. We define a logic variable E that is 1 if ABC has even parity.

(a) Write a truth table for E, that is, the combinations of ABC having even parity.

TRUTH TABLE FOR E

A	B	C	E

(b) Write a Boolean expression in sum-of-products form for E.

(c) Draw a logic circuit for E, constructed only of inverters, OR gates, and AND gates.

(d) Draw a logic circuit for E, constructed only of NAND gates and inverters.

Problem 4 (16 points) - Nodal Analysis

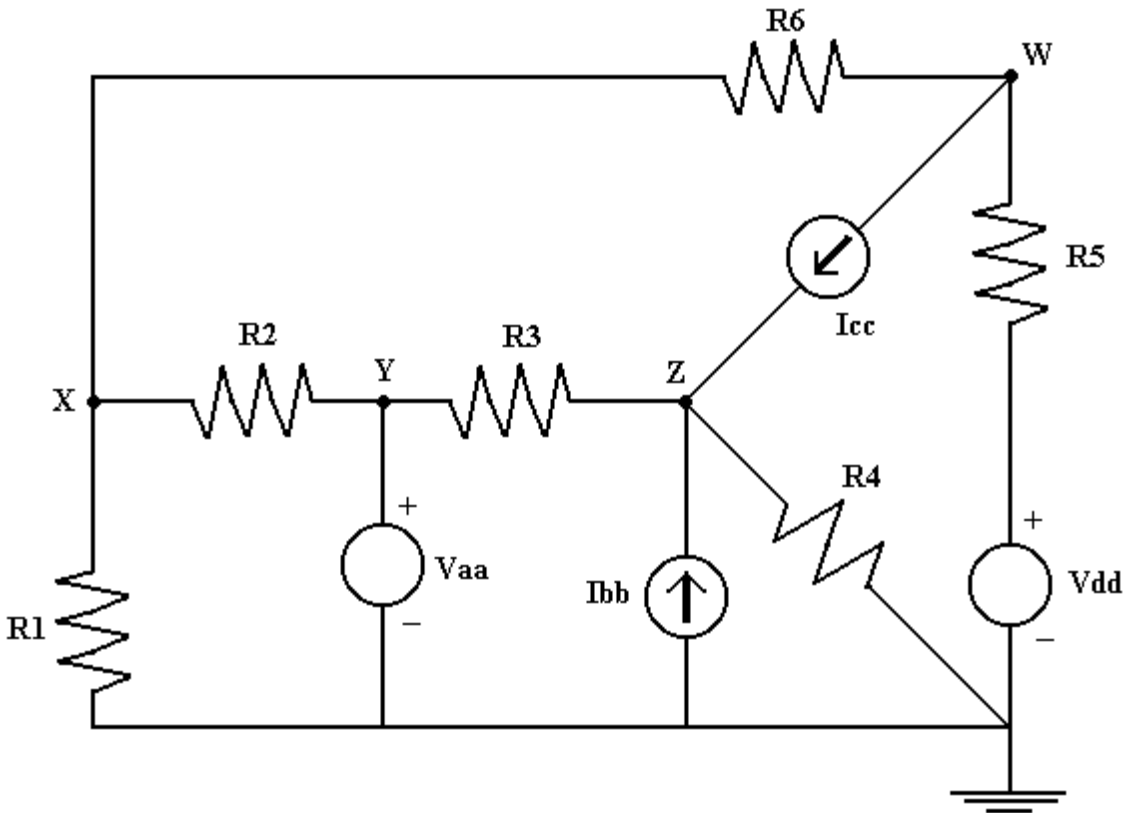

(a) In this problem you are to use nodal analysis to find a set of equations enabling you to find the values of V_X , V_Y , V_Z , and V_W . First, identify which of the four are really unknown node voltages and secondly, write sufficient equations to find the four values. Hint: If, for example, two of the voltages are known, you first write these two values (known node voltages), then you would need two nodal equations for the two unknowns.

NOTE: DO NOT solve the equations.

(b) For the circuit below, we are interested in V_a , V_b , V_c ; first identify which of these are known, and then write sufficient equations to solve for the unknown voltages. DO NOT SOLVE.

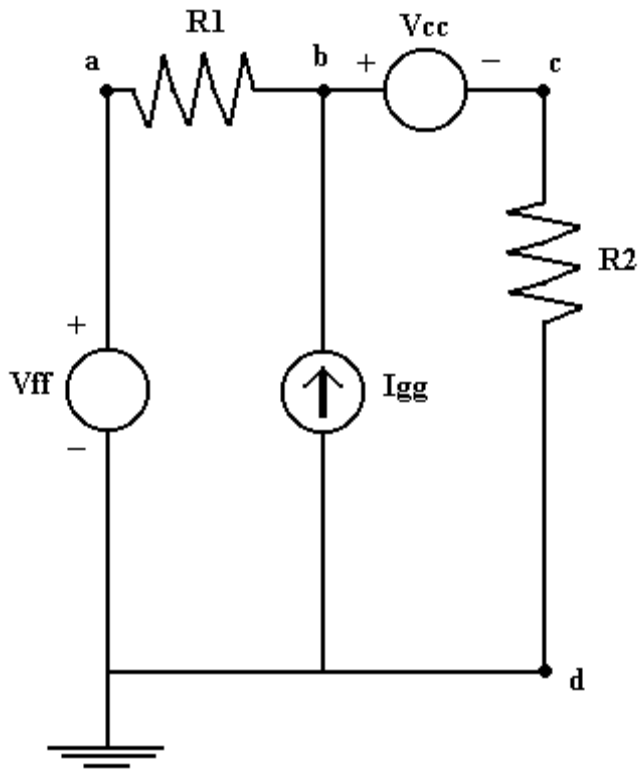

Problem 5 (16 points)

A recent Stanford graduate has designed an improvement to a BART controller logic circuit. The logic diagram is below. It has two inputs, A and B, and an output F. In this circuit the inverters, the NAND, and the AND gates all have a unit delay of 1 nsec.

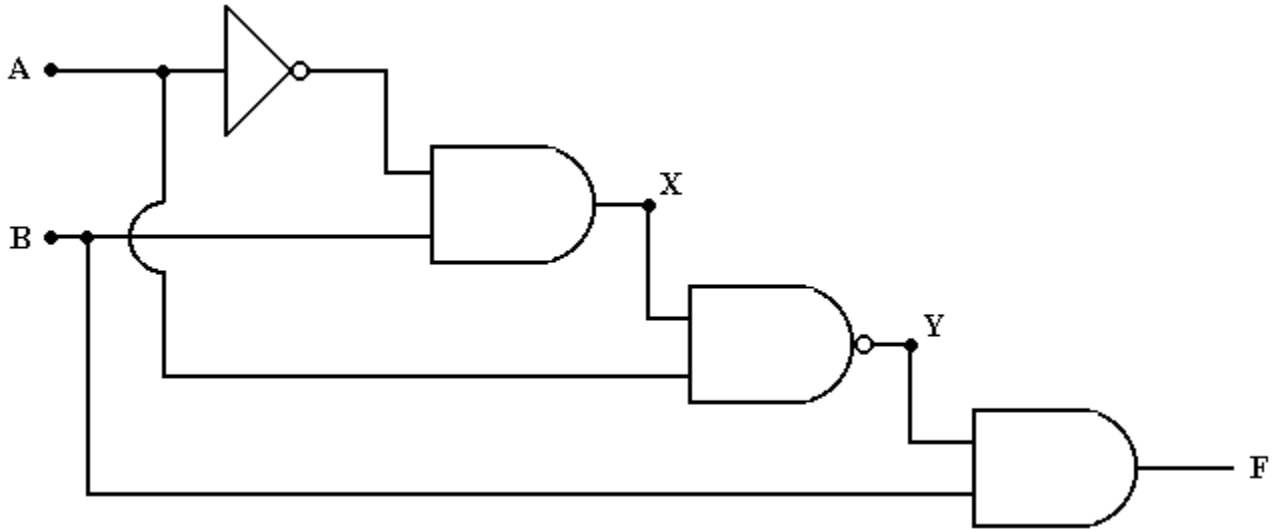

(a) Given the input waveforms for A and B versus time shown, make a neat sketch of the logic response versus time for the nodes X, Y, and F. (Assume that the values of A and B given at $t = 0$ were the same for a long time before 0.) Important: Make your timing sketch on the area provided below. Do this independently of part b. Hint: For your own use, you may want to sketch the invert of A on top of the graph for A.

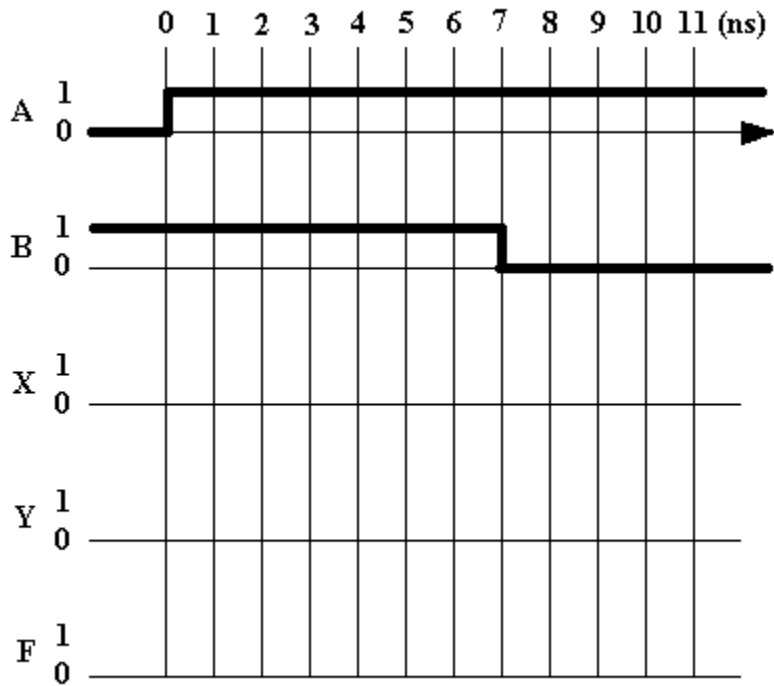

(b) Being a smart Cal student, you think it is wise to check out the work of the high-paid Stanford engineer. Can you write down the logic expression for Y and for F? To get full credit you must derive and simplify the logic expression and you must show all of your work.

Problem 6 (15 points)

(a) You find a tremendous bargain on a transmogriifier at a flea market. You do not know what it is, but it's a great big black plastic box with two terminals and it's labeled "type 1 transmogriifier," and most importantly, the price is 50 cents. You take it home and measure its I-V characteristics and plot I versus V, as shown. Now your lab partner connects the device into the circuit shown and you find the box gets warm. How much power is the transmogriifier consuming when connected this way?

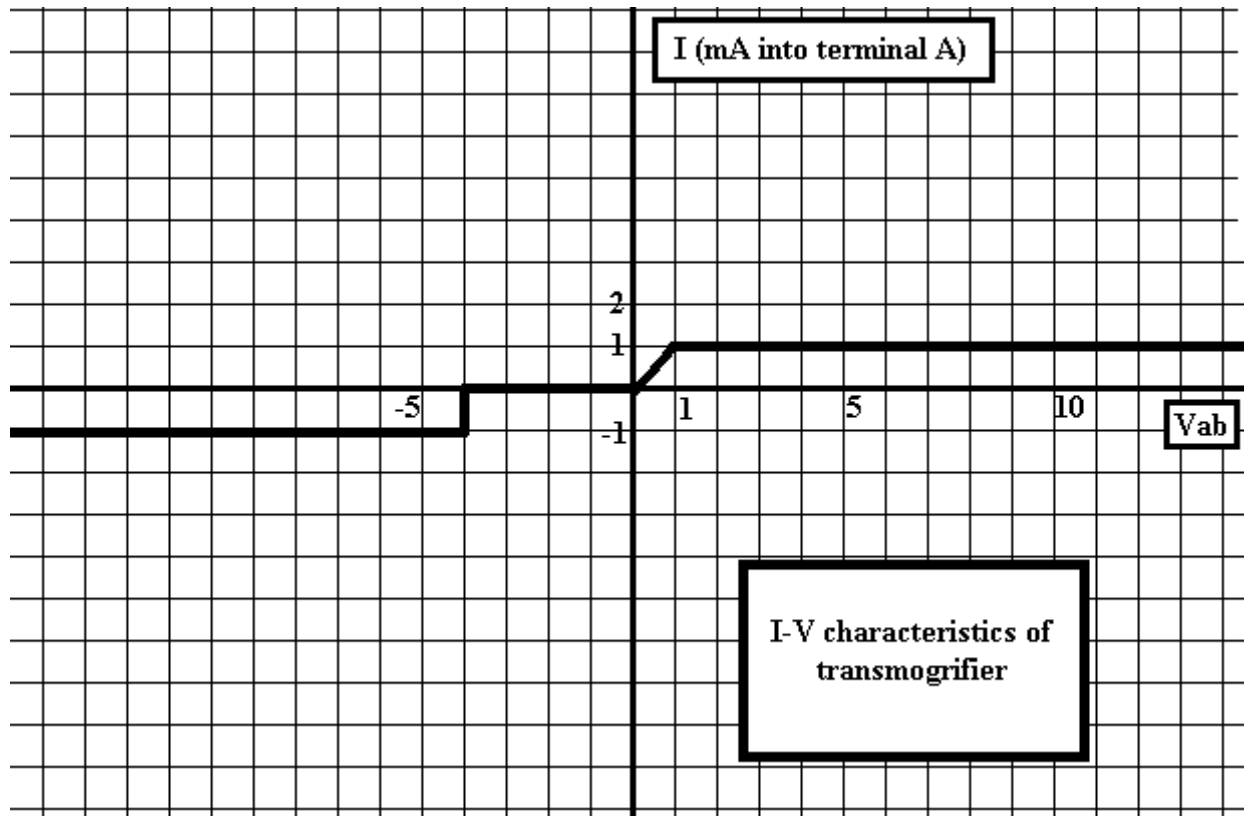
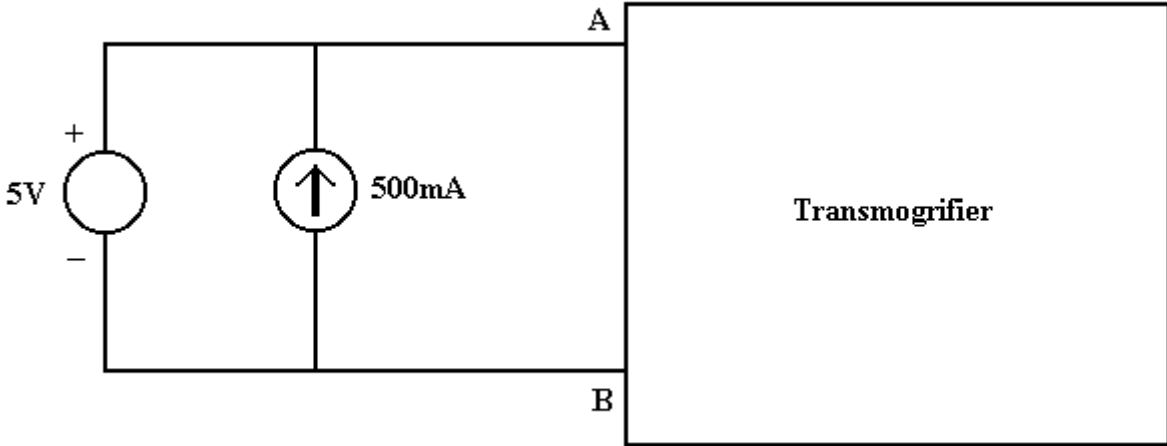

(b) Wanting to learn about the effects of electricity on exhausted college students, you prepare the experiment shown. At the output terminals, labeled "O" and "G", you intend to hook up your roommate, Charlie. You have already determined that when a suitable moist connection is made, your roommate behaves electrically like a resistance of $1\text{K}\Omega$. The idea is that you will first set some suitable value of V_{SS} , and flip the switch from the left to the right (i. e., charging the capacitor, and then discharging it into your subject.) If there is no response, you repeat the experiment but at a larger value of V_{SS} . You keep on increasing the value of V_{SS} until you elicit a response. (Then you run.)

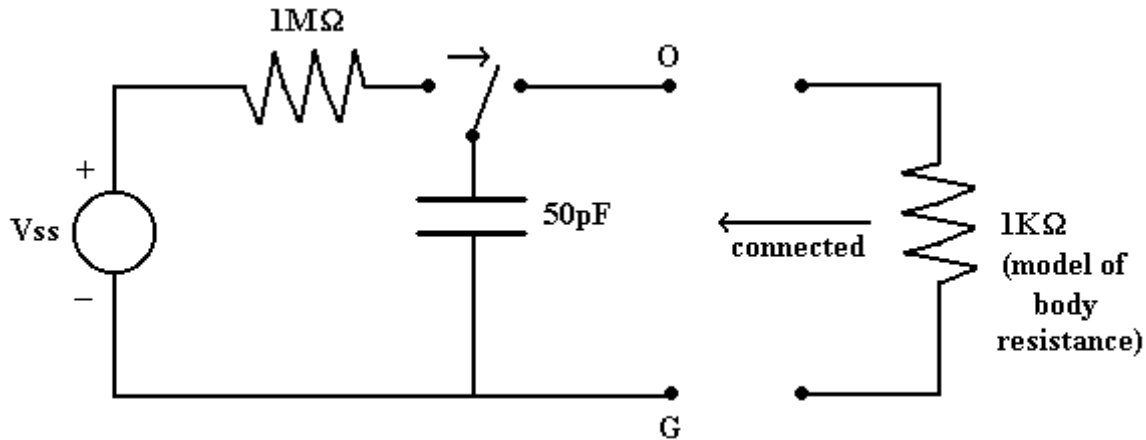

(b.1) Suppose Charlie has a response at a voltage of $V_{SS} = 1\text{KV}$. How much energy are you delivering to him in one pulse under such conditions?

(b.2) What is the efficiency of your energy delivering process, in other words, what fraction of the energy taken from V_{SS} is delivered to Charlie?

(b.3) How long should you keep the switch to the left to be sure that you have charged the capacitor to exactly 99% of the value of V_{SS} ? (Assuming the capacitor is initially uncharged.)